

Combination construction joint waterstop (KAB)

the simple, easy and safe sealing
of construction joints

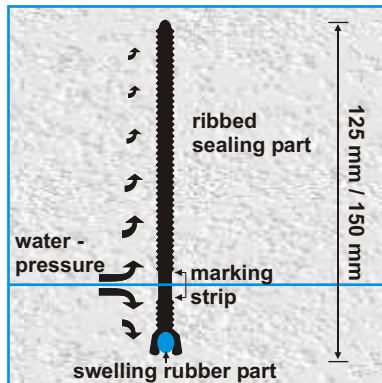

• Functional principle

The KAB profile is a waterstop with an integrated hydrophobic gasket profile used for the sealing of construction joints in concrete structures. The KAB consists of a high-grade semi-hard PVC-P material and a round swelling rubber profile (gasket) with a capacity for high volume expansion. The sealing capabilities of the KAB waterstop have been successfully tested and proven in practical use by employing concrete-encased test modules. Even under high water pressure both sealing elements - ribbed sealing and swelling profile - have proven to function in an impressive way without failure. The combination construction joint waterstops are used successfully for years in clarification plants, swimming pools, water supply tanks, basement garages and in domestic buildings.

Test certificates supporting these experiments are available on request.

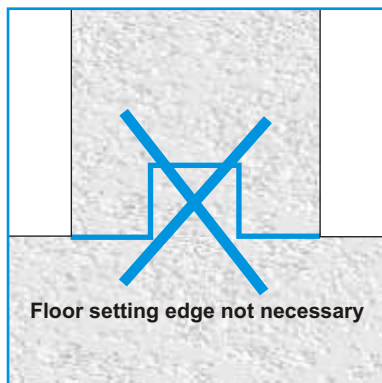

The combination construction joint waterstop is distinguished by cost effectiveness, easy installation and reliability.

- ✗ Without floor setting edge or adaptation in the reinforcement of floor sections
- ✗ Easy, quick and reliable laying
 - high inherent stability
 - coils of 25 m length which means less jointing
 - small bend radius (edges can be bent)
 - low weight (one 25 m coil is about approx. 25 kg)
 - no risk of injuries by sharp edges

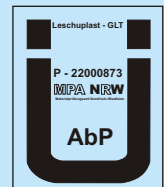

- ✗ Reliable sealing results are provided by
 - ribbed part of profile (labyrinth sealing system)
 - round swelling rubber profile (swelling pressure when expose to water)



• Application instructions (floor / wall)

The swelling rubber part of profile prevents the water from intruding into the bottom area, the ribbed part of profile prevents the water from intruding into the wall area. Installation of the KAB can be carried out at two different points of time:

- before the concrete pour
 - during or just after the concrete pour
- ✗ When installing before the concrete pour of the bottom, the KAB has to be installed directly on the bottom reinforcement by using steel bars at a distance of 0,5 m.
 - ✗ When installing during or just after the concrete pour of the bottom, the KAB with the attached steel bars will only have to be pushed into the fresh concrete. After this the concrete have to be compressed.

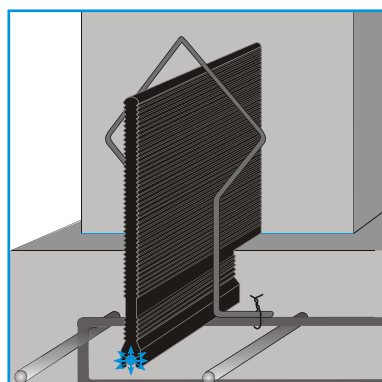

Combination construction joint waterstop (KAB)

the simple, easy and safe sealing
of construction joints



X The marking strip of 2,5 cm width is located at a height of 2,5 cm up to 5,0 cm and serves as an installation control. The max. linking depth of the profile bottom with the swelling rubber is 5,0 cm.

X Joints can be connected and installed in different ways:

- With terminal strips, which were especially developed for combination construction joint waterstops. Basic principle are 3 swelling rubber profiles with a capacity for high volume expansion and terminal strips of 2 mm thickness, which will be connected with the punched waterstop by butterfly nuts. For punching the waterstop, the terminal strip will be used as a template (5 mm drill bit). The swelling rubber profiles will be delivered prepunched and should be stuck together as pictured leftside. The butterfly nuts should be fixed hand - screwed. Connections with the terminal strips are also possible with internal and external expansion joint waterstops.
- Butt joint weldings with an axe shaped welding tool (the round swelling rubber profile can be taken out of the notch in the welding area temporarily, to remove it after the welding in the cleaned notch).
- Overlapping welding with hot air blower. The overlap should be 5 cm the riffle must be deleted on the whole width. The contact surfaces are smelting by the hot air concurrently and have to be pressed against each other.
- Parallel installation on a distance of approx. 50 cm with a gap of 5 cm (in areas under high water pressure connections with terminal strips or weldings are preferable).

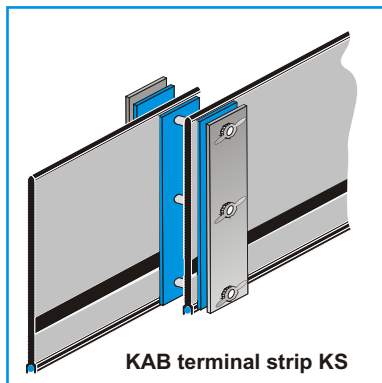

• Application instructions (wall / ceiling)

The long part of profile have to be pushed into the fresh concrete up to the marking strip, on the top of the wall during the first concrete pour section. After this the concrete have to be compressed. The round swelling rubber profile must be covered as far as the second concrete pour section will take place, to avoid a swelling ahead of time due to rain.

• Storage

The swelling rubber is activated by water contact. Therefore, it is important to provide storage in a dry place away from moisture.

